

Ezy-Drink® CP-BS Horizontal Lever Action Drinking Bubbler Tap - FI

Specification Data Sheet

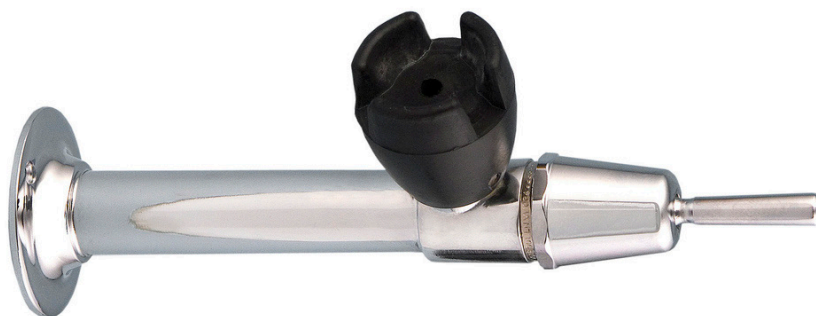

Features

- Complies with NSW Education EFSG Guidelines
- A unique rubber mouthguard has been specially designed to protect teeth in the rough and tough environment of the schoolyard and playground
- The mouthguard is made from a nitrile compound which is AS 4020 approved and has a high resistance to fungal and bacterial attack
- The rubber compound used has a high degree of saturation to ensure the unit has a greater resistance to sunlight and environmental ageing and therefore a long life in the field
- Vandal resistant design
- Inbuilt adjustment for consistency of water flow
- Easy to use self-closing mechanism
- High quality chrome finish for easy cleaning and hygiene maintenance
- Australian Made; therefore, spare parts and support are available locally, reducing costs of down time on maintenance

To Specify

Galvin Specialised AS/NZS 3718 Watermark approved, Ezy-Drink® Horizontal Lever Action Drinking Bubbler is ideal for use in playgrounds, schoolyards and public area drinking troughs.

Robust and reliable, our Ezy-Drink® Horizontal Lever Action Drinking Bubbler is water conserving and cost-effective.

Code:

TD90L - Ezy-Drink® CP-BS Horizontal Lever Action Drinking Bubbler Tap - FI



A family
owned
Australian
business



Performance Standards & Approvals

- AS/NZS 3718 – WaterMark
- WELS 6 Star Rating



Typical Dimensions

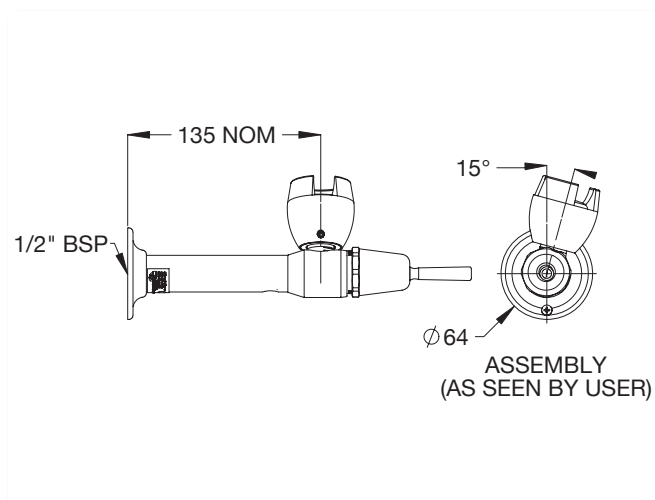

Technical Information

- Inlet: 1/2" BSP - Female
- Outlet: Rubber Mouthguard
- Headwork: Lever Action
- Working Pressure Range (kPa): 50 Min - 500 Max
- Working Temperature Range (°C): 5 Min - 60 Max
- Nominal Flow Rate (LPM): 2
- Construction: DZR Brass
- Finish: Chrome

Maintenance & Cleaning

Galvin Specialised products should be cleaned with a soft damp cloth using only mild liquid detergent or soap and water. Do not use cleaning agents containing a corrosive acid, scouring agent or solvents. Do not use cream cleaners, as they are abrasive. Use of unsuitable cleaning agents may damage the surface. Any damage caused in this way will not be covered by warranty.

Regular maintenance should be carried out in accordance with the installation and troubleshooting guides provided with the product, relevant Australian Standards, local authorities and state codes.

As part of maintaining a safe and reliable plumbing system, we recommend tapware and valves are operated on at least a daily basis.

Warranty

Galvin Engineering products are covered under our Manufacturer's Warranty at www.galvinengineering.com.au. Galvin Engineering products must be installed in accordance with the installation instructions and in accordance with AS3500 and the PCA, relevant Australian Standards and local authorities applicable to product being installed. Water and electrical supply conditions must also comply to the applicable national and/or state standards, failing to comply with these provisions may void the product warranty and affect performance of the product.

Whilst all reasonable care has been taken in compiling the information in this document, the designs, dimensions and products shown are indicative only and should not be relied upon without our prior approval. Due to our policy of continuous development, we reserve the right to alter any details of specifications or products without notice. All information, drawings, technical specifications and product designs remains the property of Galvin Engineering Pty Ltd.

Within Australia: **1300 514 074** Outside Australia: P: +61 (0)8 9338 2344
F: +61 (0)8 9338 2340
sales@galvinengineering.com.au
www.galvinengineering.com.au
ABN: 78 008 719 382

A business unit of
GalvinEngineering
the mark of reliability 

PERTH | SYDNEY | MELBOURNE | BRISBANE | ADELAIDE | UNITED STATES OF AMERICA | UNITED KINGDOM | NEW ZEALAND